

Strategies in Light®

The Leading Events for the Global LED and Lighting Industry

Interpreting Luminaire Labels and Awards

Avraham Mor, IALD, LEED AP, IESNA
Partner, Lightswitch Architectural



LIGHTSWITCH
ARCHITECTURAL



Labels & Awards

- National Testing Laboratories (NTL)
- Energy Star
- Lighting Facts Label
- Lighting for Tomorrows (LFT)
- Next Generation Luminaires (NGL)

Why do we need this?

GOOD

- Color
- Size
- Energy Use
- Output
- Energy Star
- Innovation
- Binning
- NGL & LFT

BAD

- Mrkt Confusion
- Energy Use
- Energy Star
- Fake Labels
- Too Bright
- Binning
- Dimming
- Shadows
- Flicker
- Maintenance
- End of Life
- Green Washing



LIGHTSWITCH
ARCHITECTURAL

System Parts

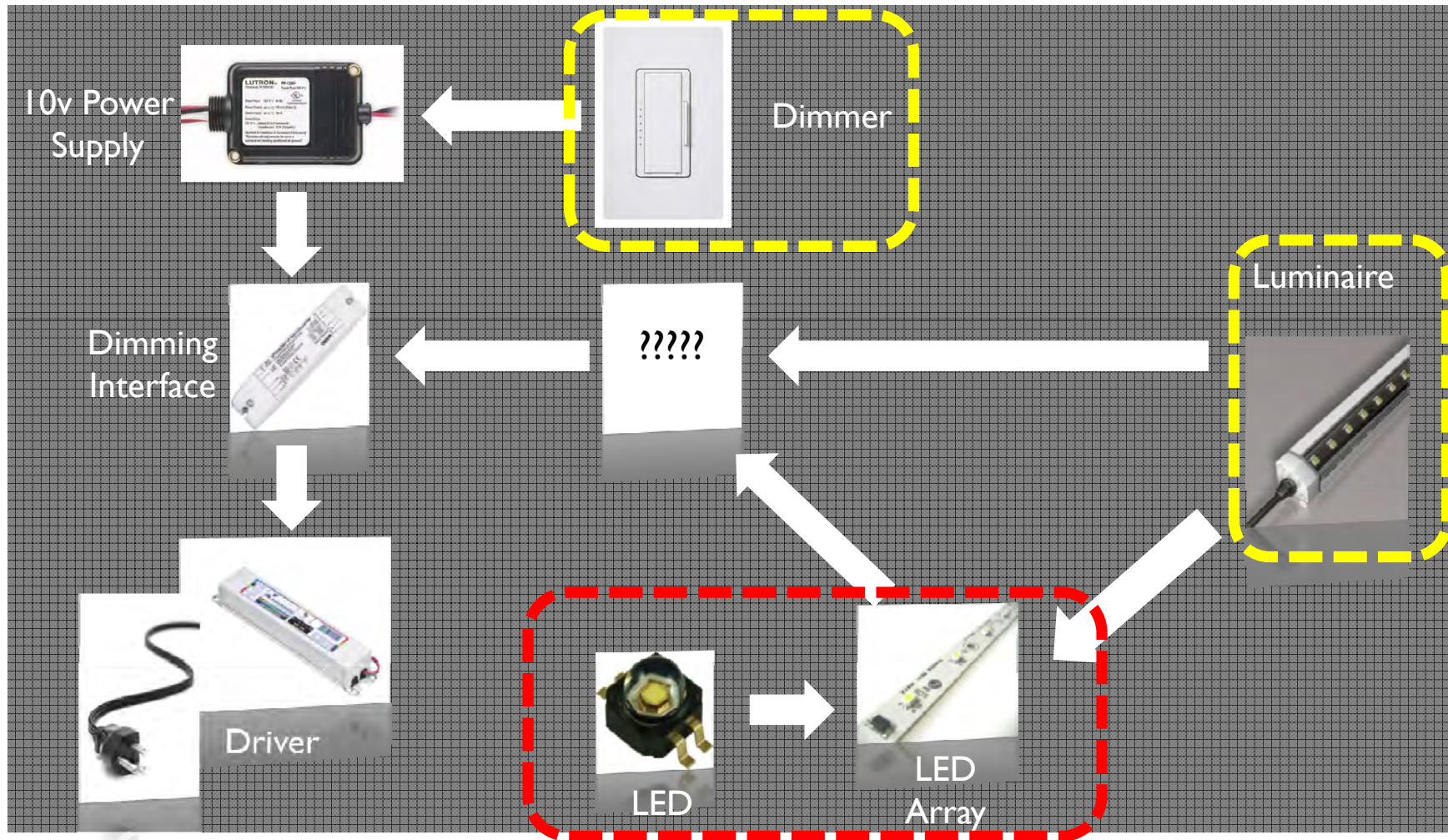

Color

- CRI / CCT
- SPD
- Binning
- Date Codes

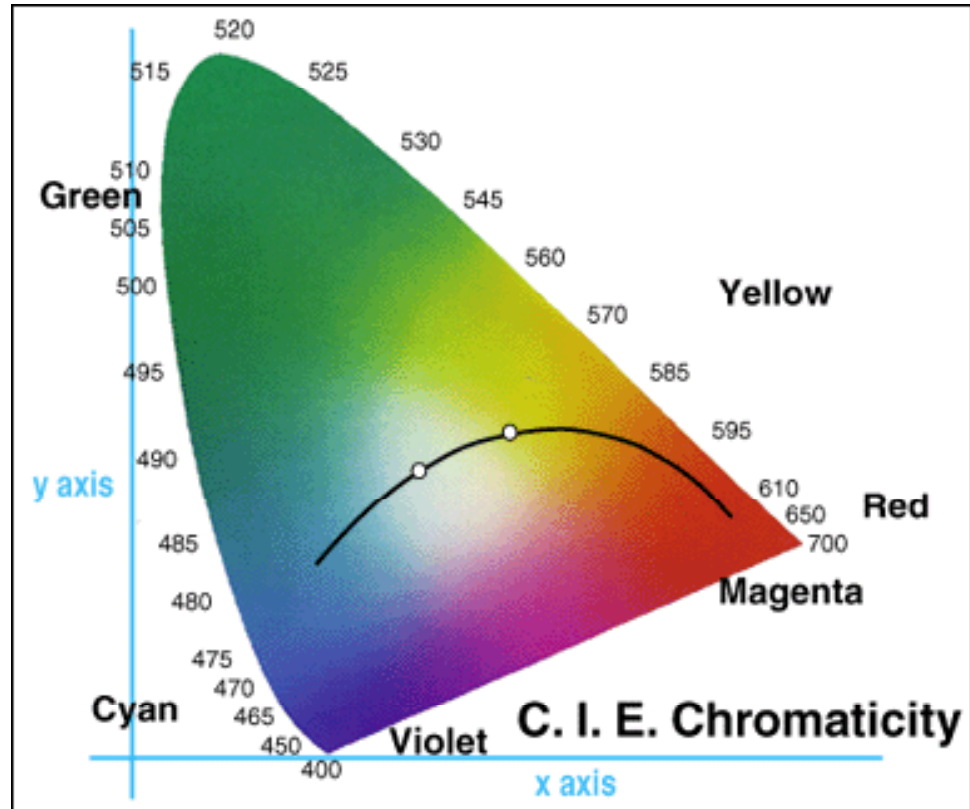

Color



Color

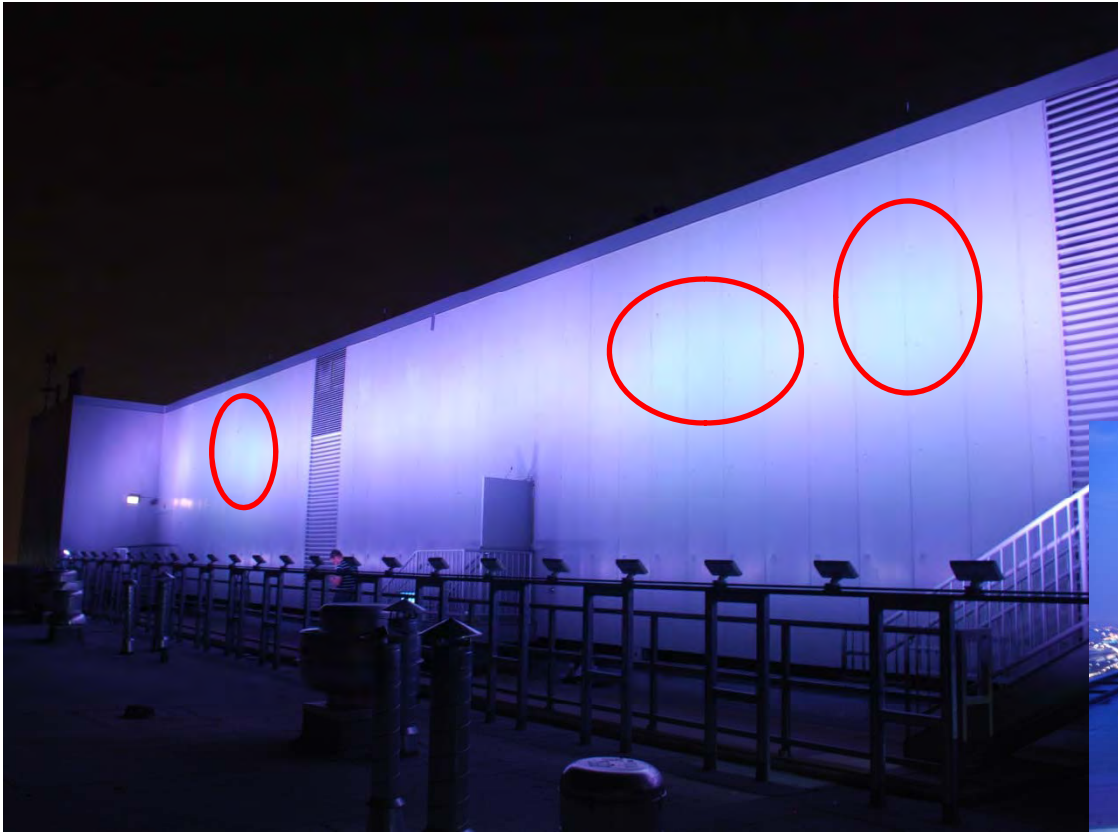

Dimming

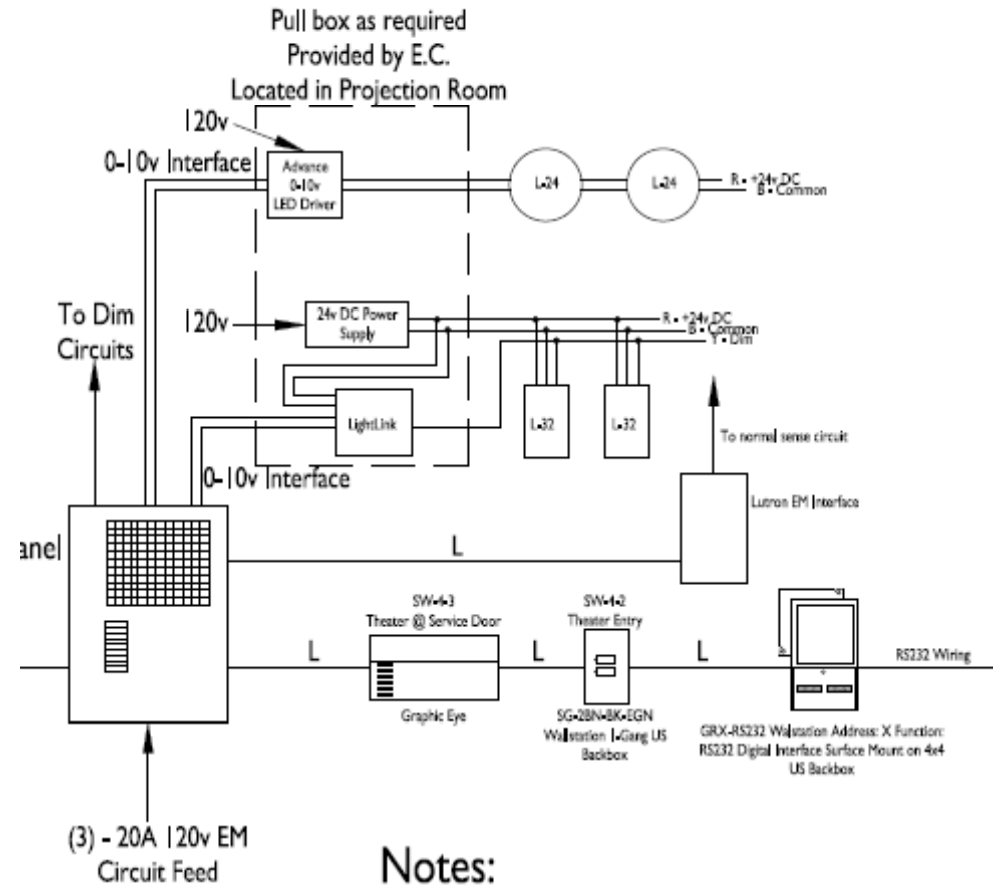

Drivers & Dimming



Manufacturer	Model	Description	Dimming range
Lutron	Hi-lume LED driver	Driver	100% - 1%
Advance	Xitanium	Current Driver	Not Specified
Advance	Xitanium	PWM Driver	100% - off
Color Kinetics/Philips	eW PowerCore	Strip Light	100% - 15%
Color Kinetics/Philips	eW Profile : 11"	Under Cabinet Strip Light	100% - 15%
Color Kinetics/Philips	eW Profile : 41"	Under Cabinet Strip Light	100% - 15%
Color Kinetics/Philips	eW Downlight	Downlight	100% - 15%
Cooper/Halo	Downlight	6" round downlight	
Cree/LLF	LR4	4" Downlight	100% - 20%
Cree/LLF	LR6	6" Downlight	100% - 20%
Cree/LLF	LR6 - 230V	6" Downlight	100% - 20%
Cree/LLF	LR24	24" x 24"	100% - 5%
GE Lumination	LED Cove light	Cove Light	100% - 3%
Juno	Track	Cove Light	Not Specified
Osram/Sylvania	OT Dim	Driver	100% - Off

Serviceability

How is the “Lamp” going to be changed?



National Testing Labs

- Underwriters Laboratories – UL
- Intertek – ETL
- Canadian Standards Association – CSA

NTL listing is **REQUIRED** for commercial use of **ANY** electrical product



NTLs

- Some products certified by NTLs are components that are intended to be used in the manufacture of a complete Listed product. These components **cannot** bear the NTLs symbol, but may use a special Recognized Component Mark.

NTLs

- The NTLs Mark on a product means that the NTL has tested and evaluated representative samples of that product and determined that they meet the NTLs requirements. The NTLs Marks may be **only** used on products certified by the NTL and under the terms of written agreement between the manufacturer and the NTL.

DOE SSL Energy Star Criteria

- Commercial & Residential
- 8 nominal CCTs
- 4-step Color Spatial Uniformity
- 7-step Color Maintenance
- CRI ≥ 75 for indoor
- Off-state Power prohibited
 - Exception for integral controls, limited to 0.5W
- 3 Year Warranty
- **Thermal Management**



Energy Star

Certification Mark



Use the Certification Mark as a label on products, homes, and buildings that meet or exceed ENERGY STAR performance guidelines.

See special applications:

- Insulation (pages 9.2-9.3);
- HVAC (pages 6.6-6.7).

Partnership Marks



Use the Partnership Mark to promote an organization's commitment to and partnership in the ENERGY STAR Program.

4.2





DOE Awards



Our SSL Requirements

- LM-79 Photometry & Independent lab test report
- LM-80 data & heat testing of luminaire
- Written 5-Year Warranty including all system components **and reasonable** labor
- See at least two samples of the same CCT
- Written Luminaire Binning policy
- Written Luminaire End of Life policy
- Energy Star & Lighting Facts Label
- NGL, LFT, and/or Caliper reviewed



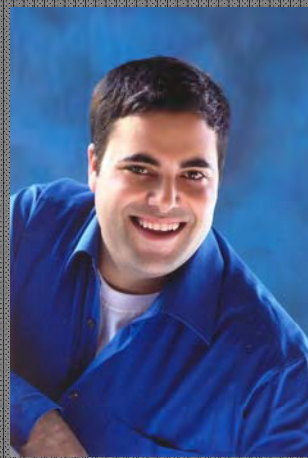
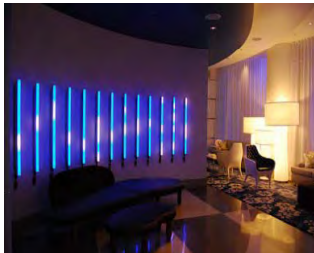

**Avraham M. Mor, IALD,
LEED AP, IESNA**
Partner , Lightswitch Architectural

amor@lightswitch.net
312.288.8777 x101

architecture.lightswitch.net
avisblog.architecture.lightswitch.net

Lighting Your Vision with Responsible Design™

Lightswitch Architectural is a premier architectural lighting design firm whose cutting edge lighting designs make it a leader in the industry. Known for innovation, attention to detail, professionalism and client service, we have a proven track record of delivering designs that are exciting, dynamic and visionary – on time and on budget.

Principals and staff members are highly trained industry professionals who understand the importance of communication. We work with property owners, developers, architects and property managers on projects such as corporate offices and exteriors, residential properties, museums, schools, outdoor events and hotels.

